

## Table of Contents

### Motor Driven



### Motorized Rotary Tables

B4800TS	2.50
B5990TS	2.52

**Note:** Throughout this catalog you'll see **Keywords in RED**. To get more information, including access to drawings, specs, photos of examples and the latest innovations, go to our web site, [www.velmex.com](http://www.velmex.com), and enter the corresponding **Keyword in the Quick Search Box**.



## Rotary Tables

Velmex offers two sizes of every table: Series B4800TS (4.9" diameter) and Model B5990TS (1.65" diameter).

### B4800TS

B4800 is a Series of three Rotary Tables that use a worm and gear drive design with a central rotating ball bearing. Gear ratios are: 18, 36, and 72:1. Models with 18 or 36 gear ratios require holding torque to maintain position. The tables can be driven by frame size 23 stepper motors, Bodine Type K or Pittman PM DC motors.

All tables have a hollow spindle or clear aperture for optical applications, an 360° scale and an adjustment to minimize gear backlash. They can be attached to the slider of the 4000 and the 6000 UniSlide Assemblies via the B6000TX adapter plate. Also mounts to BiSlide with MSPP-3 adapter plate. Plate is 6" x 6" x 1/4".

#### Options:

- Black anodized finish (see previous page)
- Magnetic reed home switch option
- Encoders on motor shaft extension

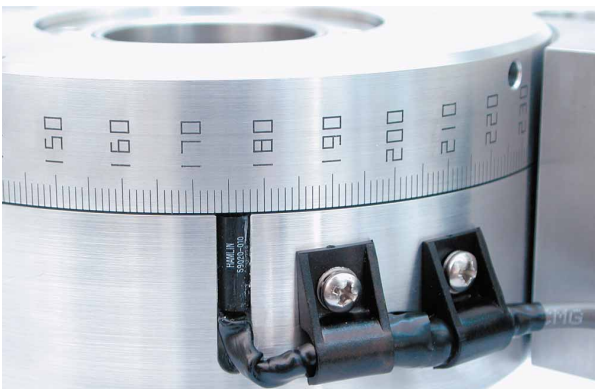

Magnetic reed homes switch option

## Mounting B4800TS

**Anchoring table base:** There are two approaches to securing the base of the table. First, there are two clearance holes for 10-32 UNF cap screws for attachment from above through the top access hole. Alternatively, to attach with screws from below, there are four threaded holes. They are 1/4-20 x 7/16" UNC on a 4" diameter bolt circle.

Series B4800TS	
Horizontal load capacity	200 lbs.
Vertical load capacity	25 lbs.
Cantilever load (Horizontal)	500 in.-lbs.
Table top axial runout	0.00025" TIR
Table top radial runout	0.0005" TIR
Accuracy	100 arc-seconds
Repeatability	1 arc-seconds
Table weight	5.5 lbs./2.5 kg.
Maximum input shaft torque	150 oz.-in.
Maximum input shaft speed	600 RPM.

**Keyword:** worm



Rotary encoder mounted to motor shaft extension

Model B4800TS

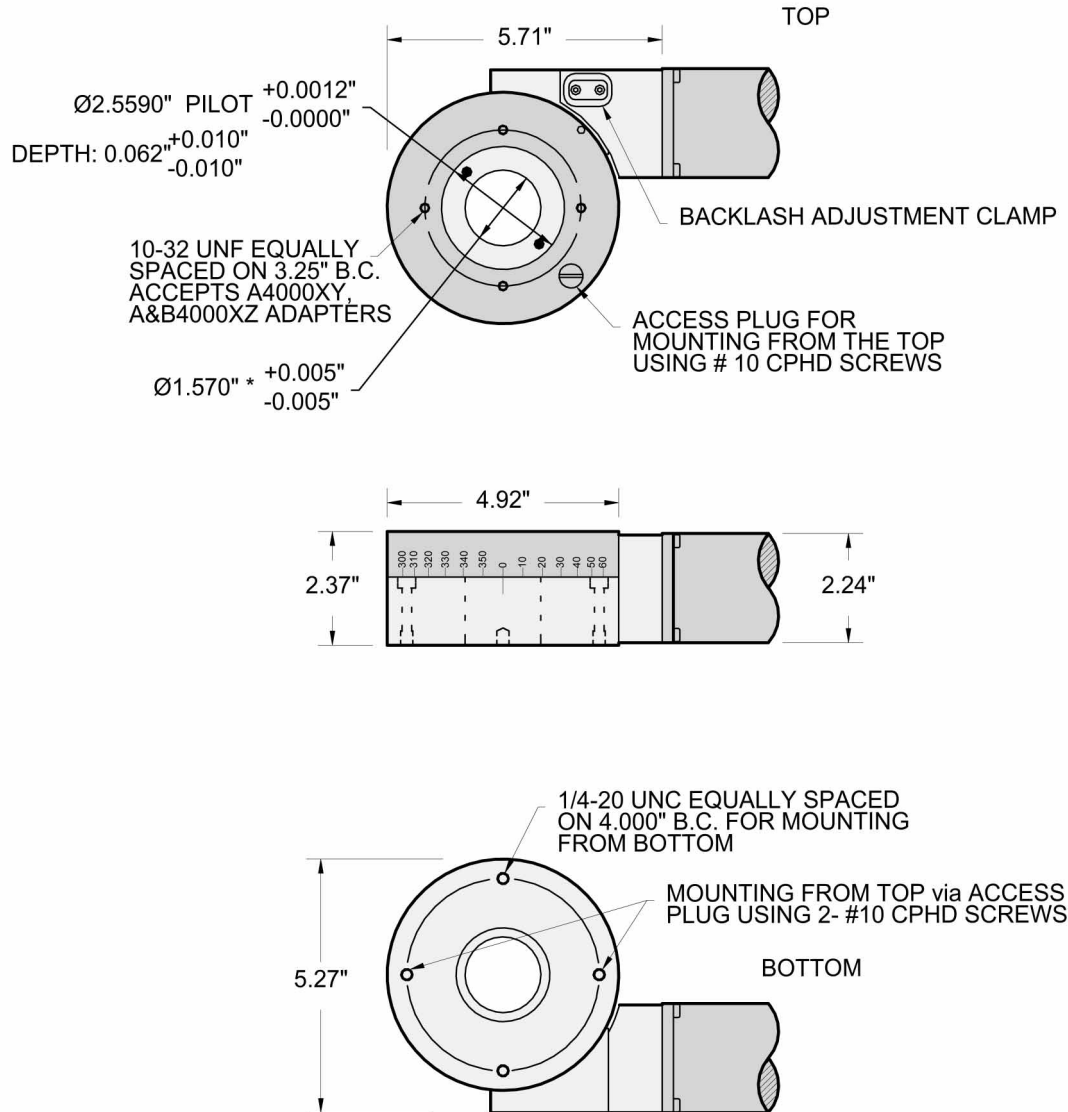

Model Number	Gear Ratio	RPM	At maximum input 600 RPM		Degree per Step	Typical Backlash
			Time per Revolution	Speed		
B4818TS	18:1	33.3	1.8 seconds	200°/second	0.050°*	600 arc-second
B4836TS	36:1	16.7	3.6 seconds	100°/second	0.025°*	400 arc-second
B4872TS	72:1	8.3	7.2 seconds	50°/second	0.0125°*	200 arc-second

\*Degree per step values are based on 400 steps/revolution using a 1.8 degree step motor and a Velmex VXM motor controller operating in half step mode.



Model B5990TS A 1.7" diameter table with a gear ratio of 90:1

### Model B5990TS Rotary Table

B5990TS Rotary Table is our smallest table, has a 90:1 gear ratio, and is lower in cost. The table price includes a NEMA 17 stepper.

Series B5990TS	
Horizontal load capacity	50 lbs.
Vertical load capacity	5 lbs.
Cantilever load (Horizontal)	20 in.-lbs.
Table top axial runout	0.00011" TIR
Table top radial runout	0.00008" TIR
Accuracy	100 arc-seconds
Repeatability	1 arc-seconds
Table weight	2.7 lbs. with motor
Maximum input shaft torque	50 oz.-in.

**Options:**

Home switch/Zero reference switch (See photo on web site)

Model Number	Gear Ratio	RPM	At maximum input 600 RPM		Degree per Step	Typical Backlash
			Time per Revolution	Speed		
B5990TS	90:1	6	9 seconds	40.2°/second	0.010°*	160 arc-second

Rotary table speed is a function of motor and driver choice. \*With 400 step/rev motor.

**Model B5990TS**

